

# Physical Computing

<http://itp.nyu.edu/physcomp/>

Hans-Christoph Steiner  
hansi@nyu.edu

Thursday, Oct. 18th, 2007

Questions?

# project presentations

- laptops closed, please!
- 10 minute presentation
- 5 minutes of questions
- next group setup during Q&A
- group order: 3, 4, 1, 2

# transistors

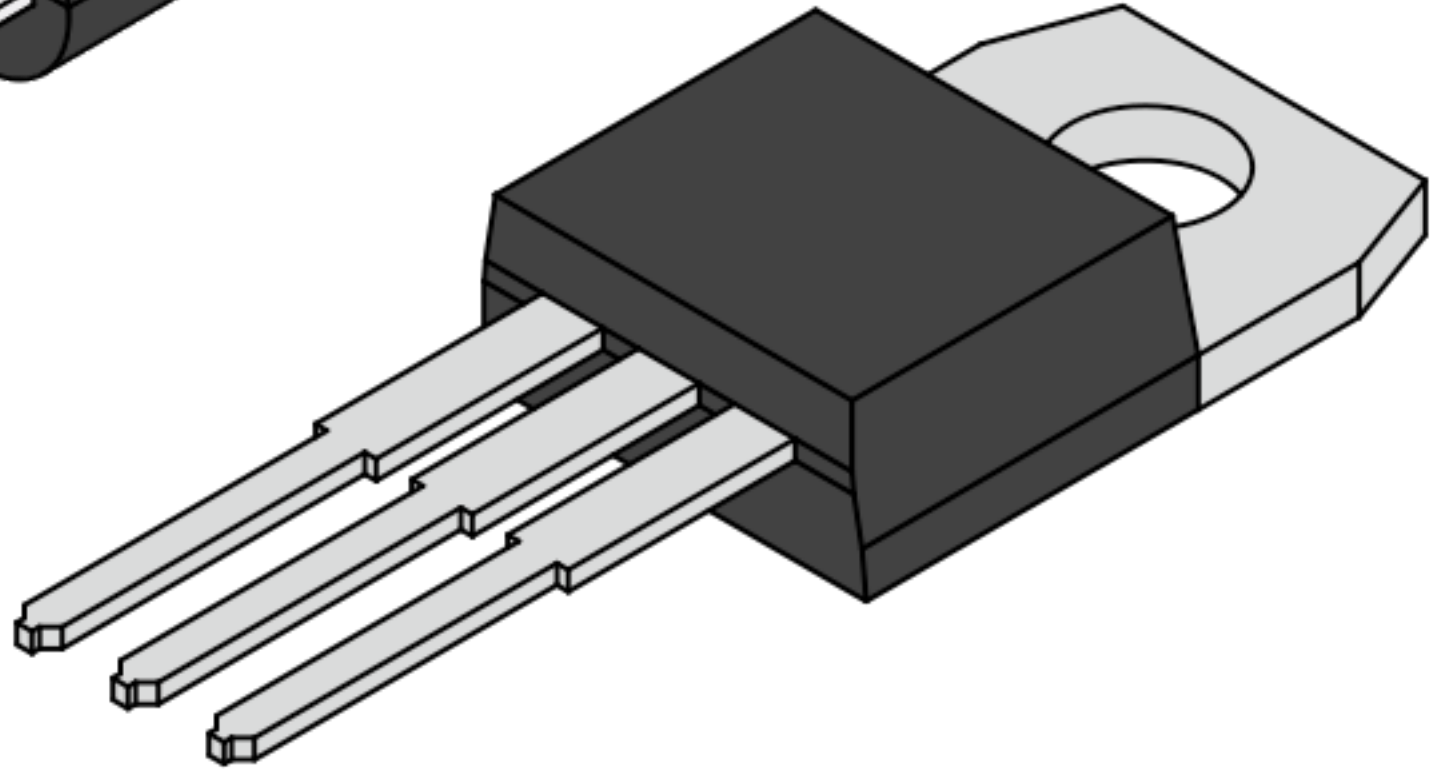
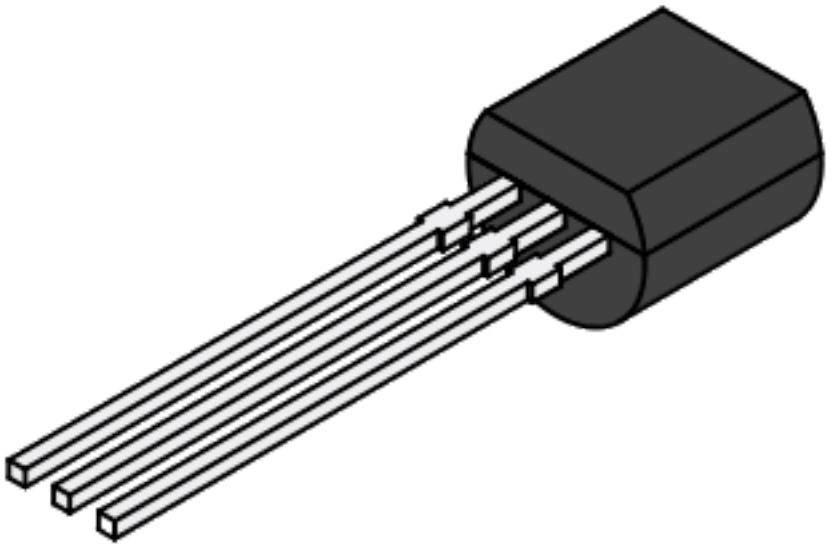
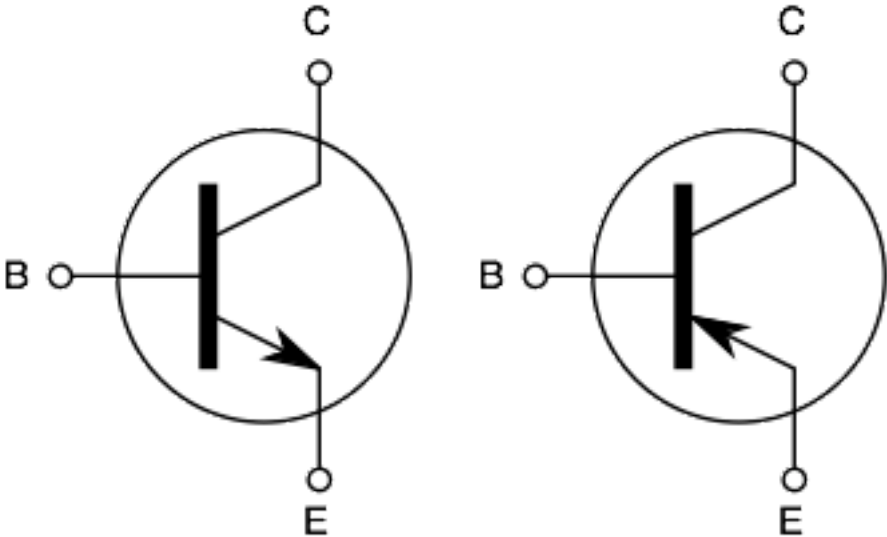

[http://commons.wikimedia.org/wiki/Image:Tranzystor\\_PNP\\_Symbol.svg](http://commons.wikimedia.org/wiki/Image:Tranzystor_PNP_Symbol.svg)  
[http://commons.wikimedia.org/wiki/Image:TO-92\\_Front.svg](http://commons.wikimedia.org/wiki/Image:TO-92_Front.svg)

[http://commons.wikimedia.org/wiki/Image:Tranzystor\\_NPN\\_Symbol.svg](http://commons.wikimedia.org/wiki/Image:Tranzystor_NPN_Symbol.svg)  
[http://commons.wikimedia.org/wiki/Image:TO-220\\_Front\\_Coloured.svg](http://commons.wikimedia.org/wiki/Image:TO-220_Front_Coloured.svg)

# controlling flow - closed

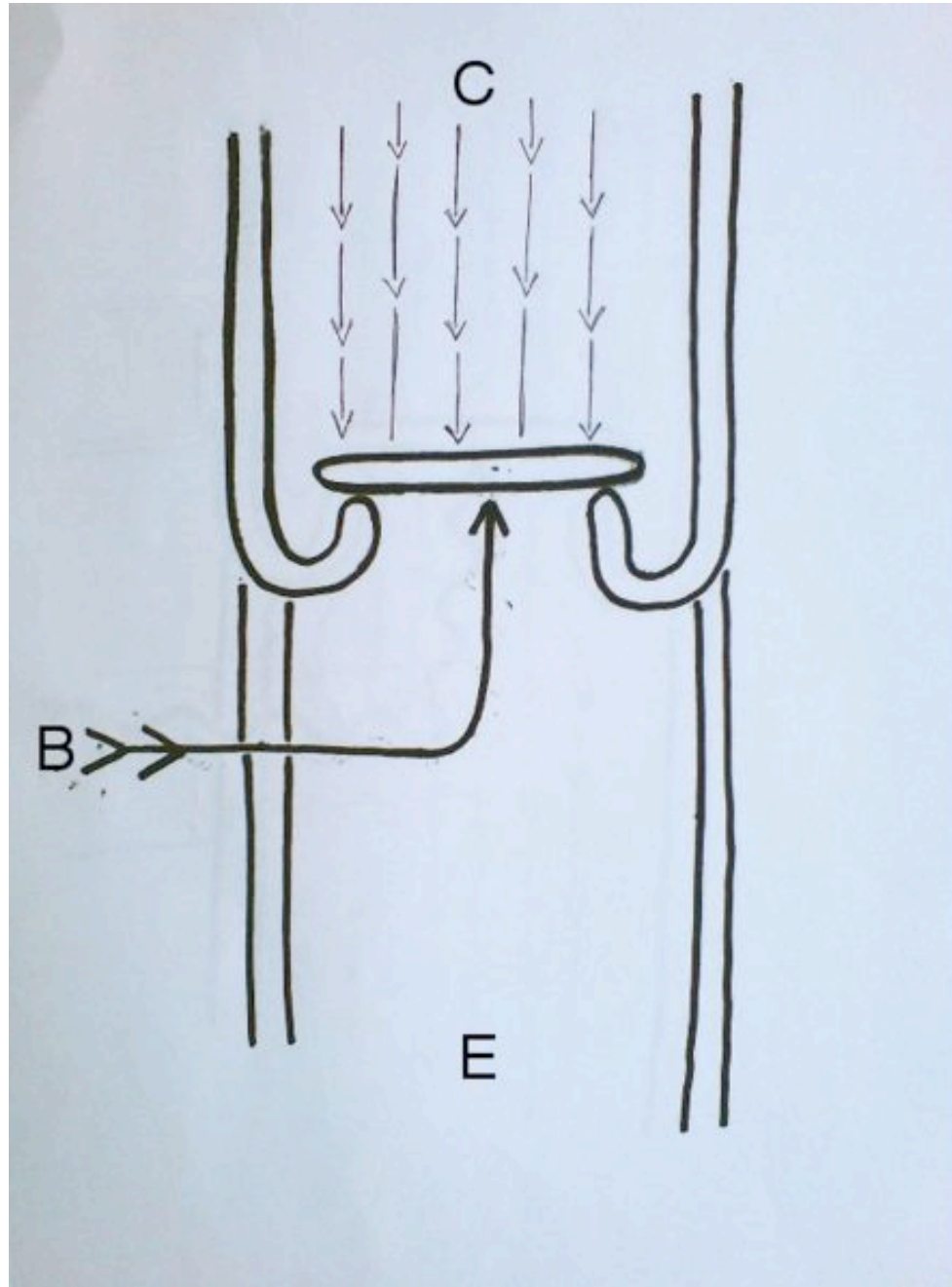

# controlling flow - open

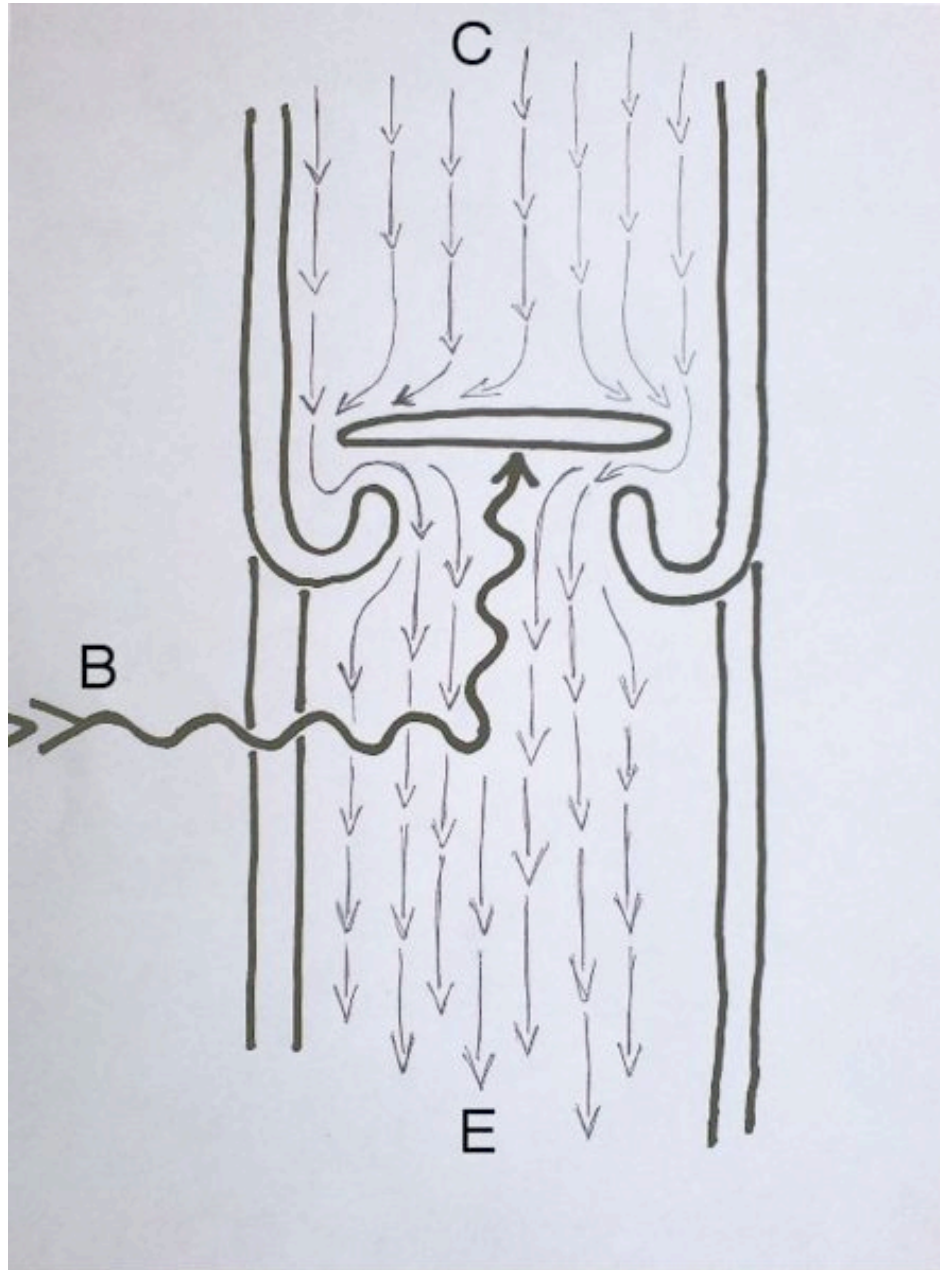

# electric charge effects

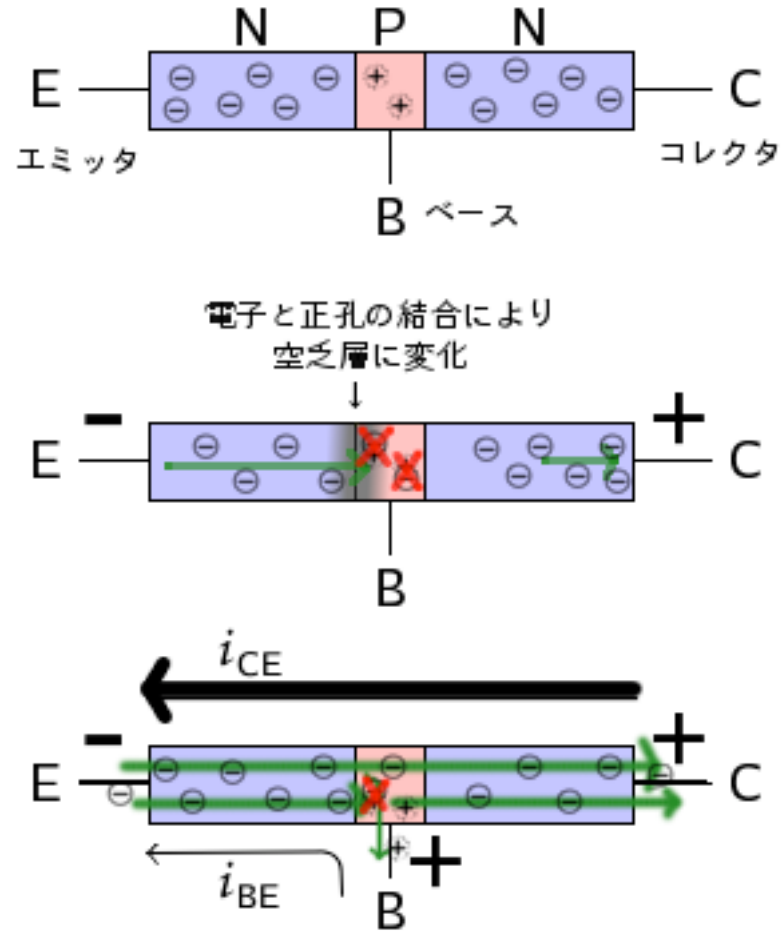

# the actual transistor

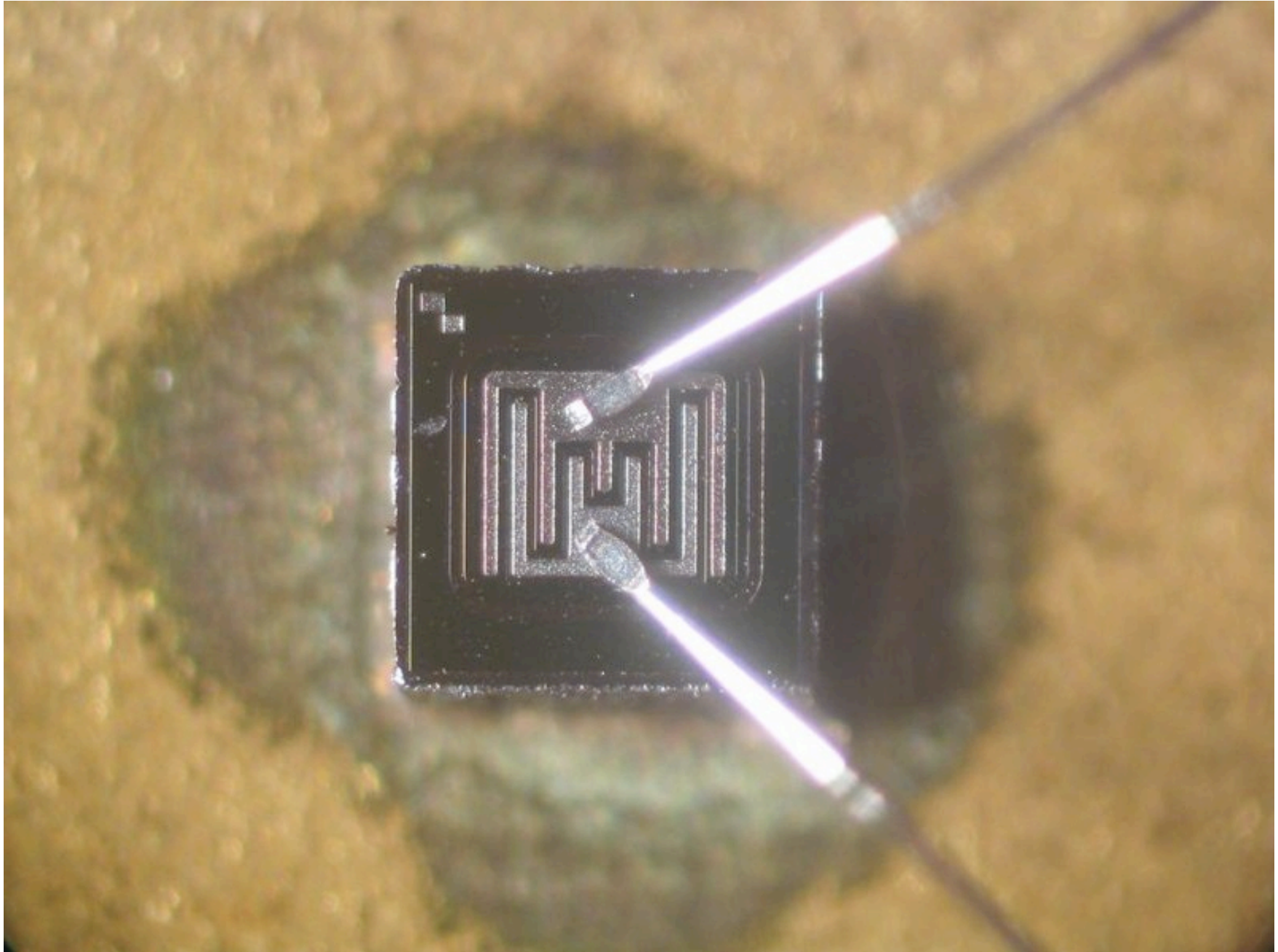

# DC motors

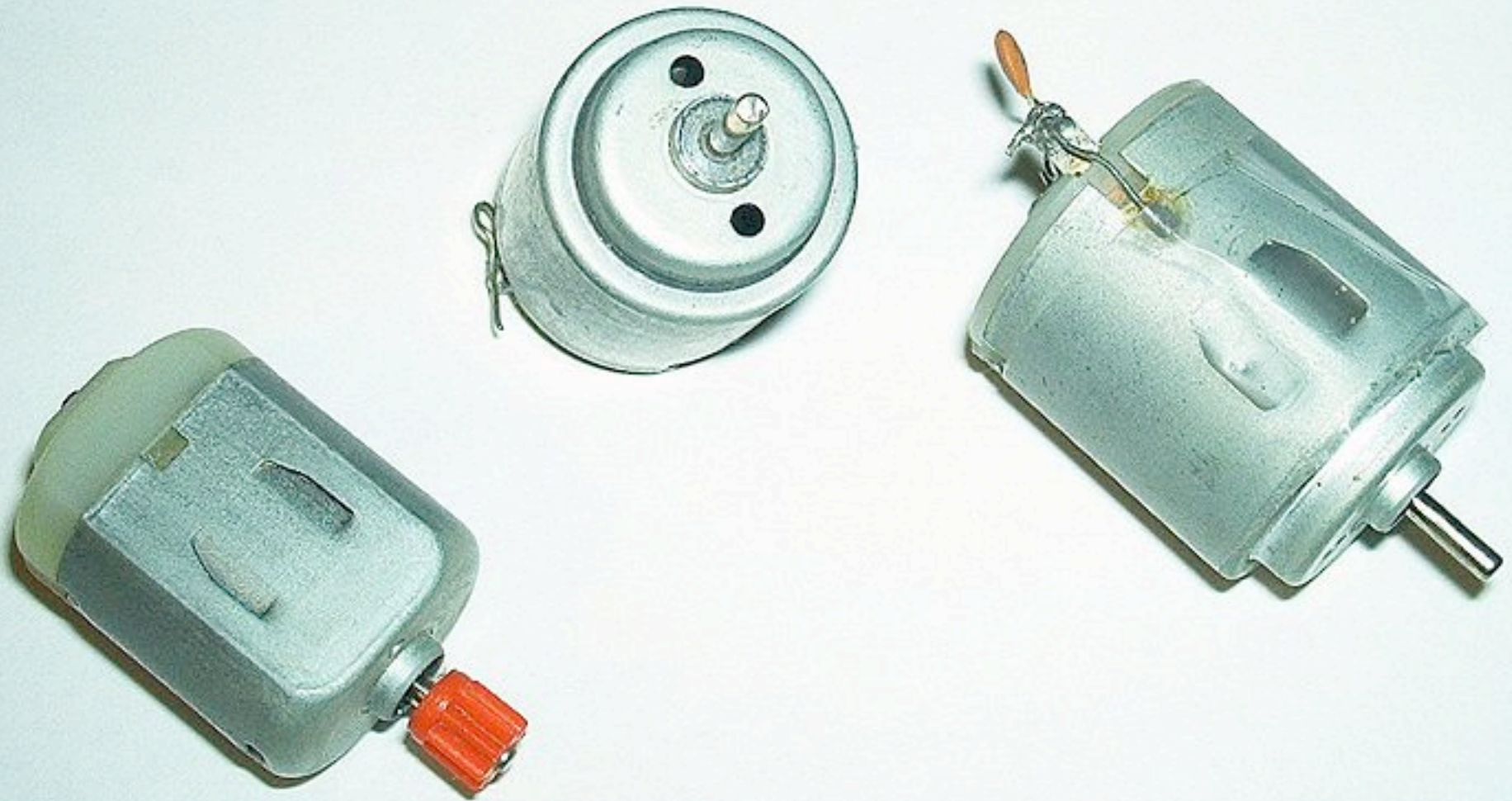

# DC motor

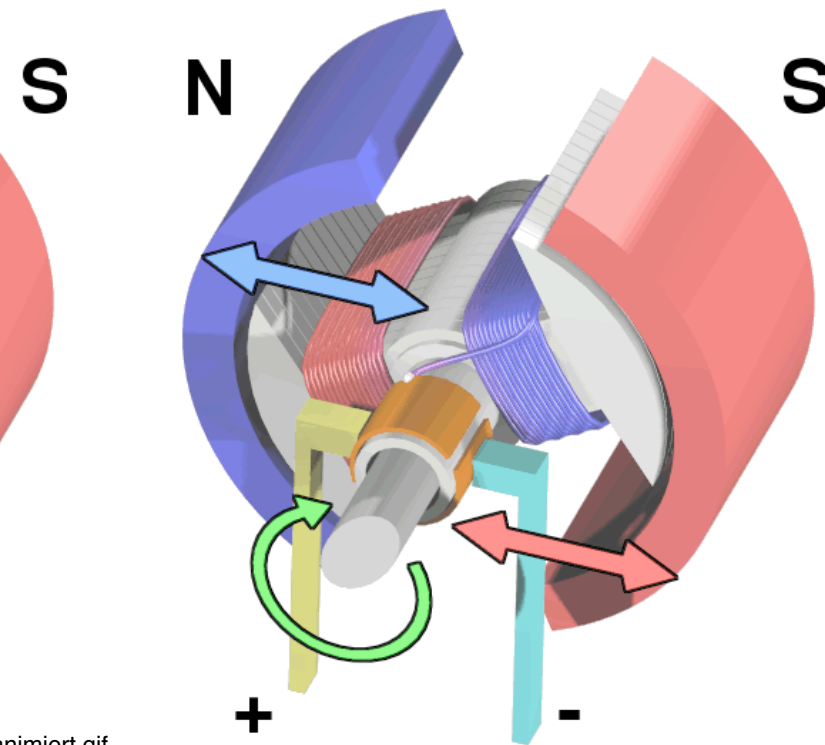
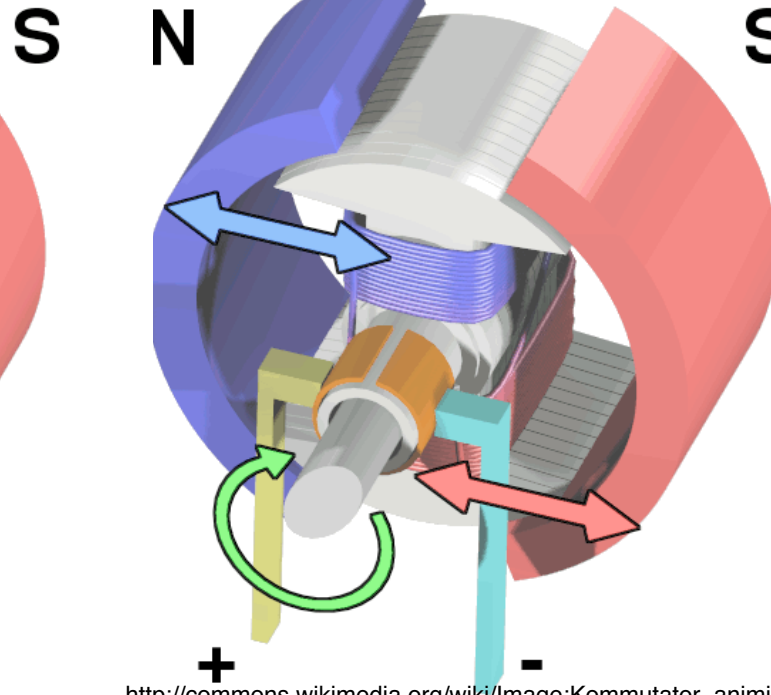
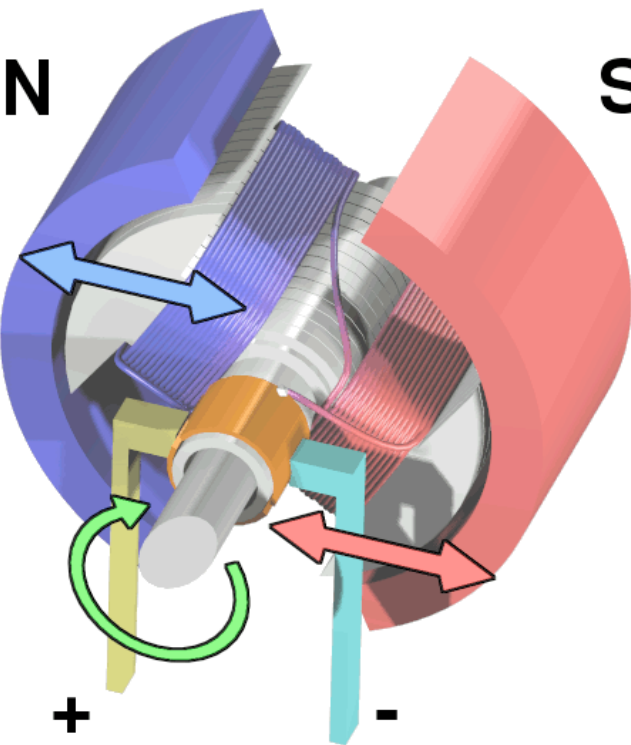
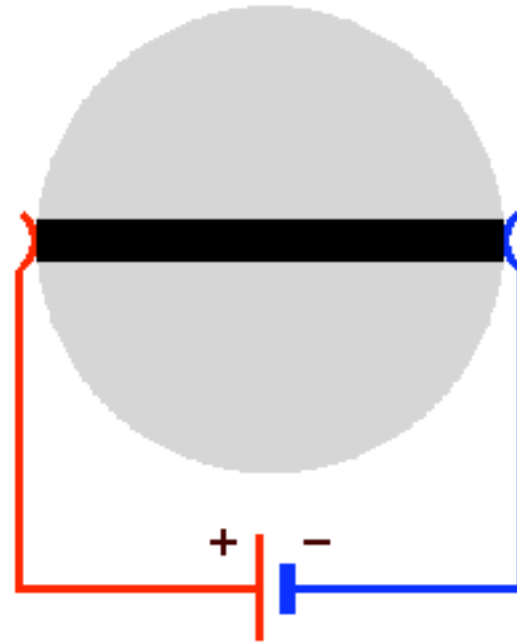

[http://commons.wikimedia.org/wiki/Image:Kommutator\\_animiert.gif](http://commons.wikimedia.org/wiki/Image:Kommutator_animiert.gif)

[http://en.wikipedia.org/wiki/Image:Electric\\_motor\\_cycle\\_1.png](http://en.wikipedia.org/wiki/Image:Electric_motor_cycle_1.png)

[http://en.wikipedia.org/wiki/Image:Electric\\_motor\\_cycle\\_2.pr\\_](http://en.wikipedia.org/wiki/Image:Electric_motor_cycle_2.pr_)

[http://en.wikipedia.org/wiki/Image:Electric\\_motor\\_cycle\\_3.png](http://en.wikipedia.org/wiki/Image:Electric_motor_cycle_3.png)

# stepper motor

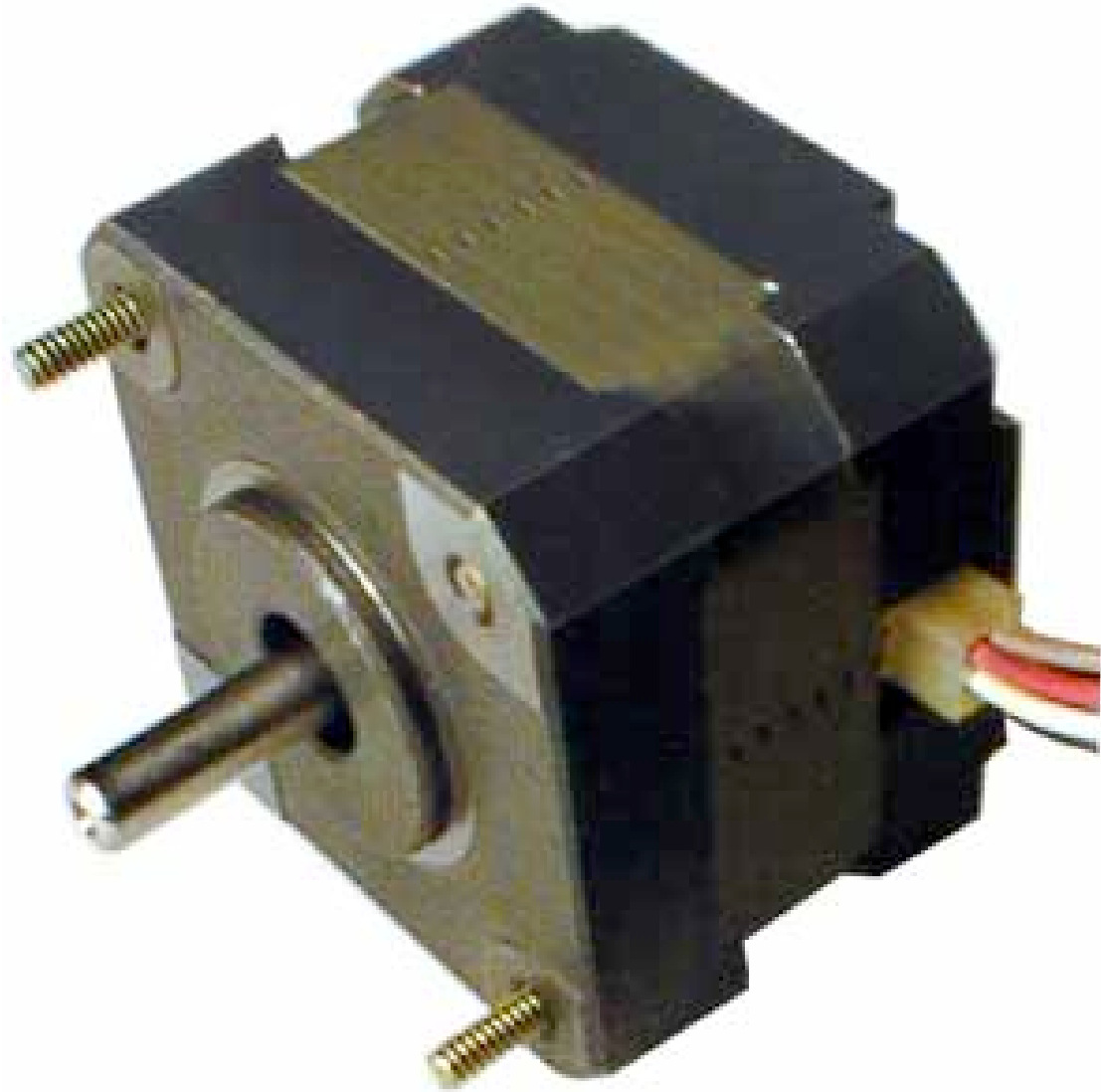

# a basic stepper motor

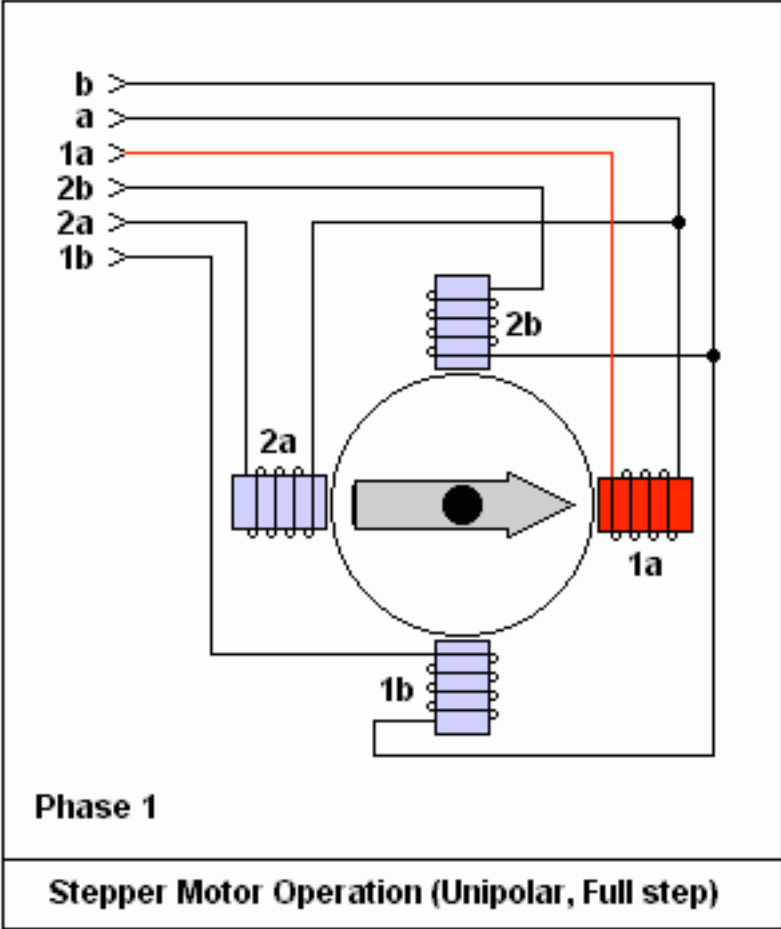

# fine-grained steppers

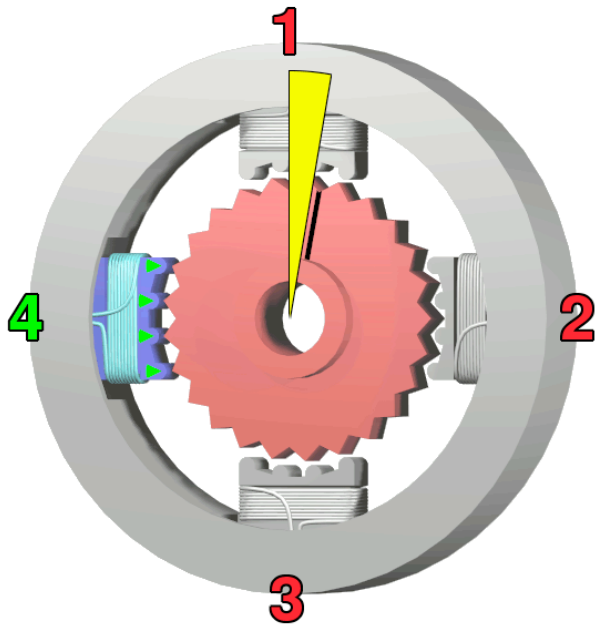
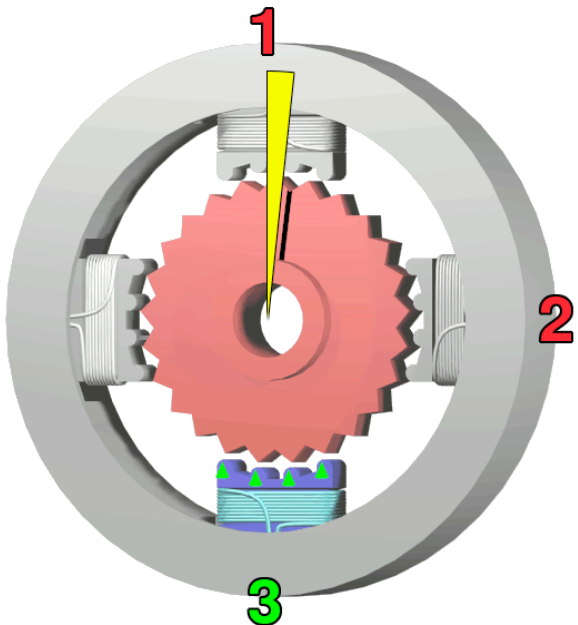
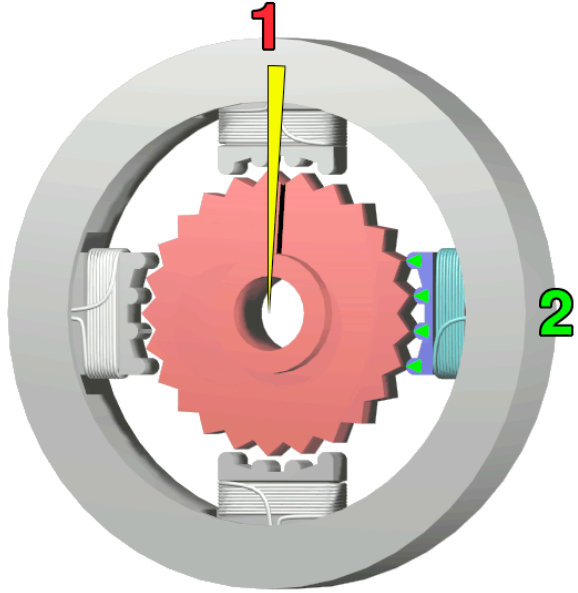
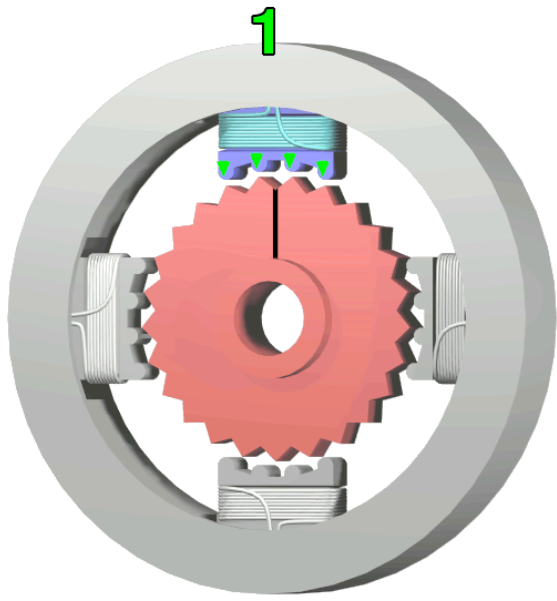

[http://en.wikipedia.org/wiki/Image:Stepper\\_motor\\_1.png](http://en.wikipedia.org/wiki/Image:Stepper_motor_1.png)  
[http://en.wikipedia.org/wiki/Image:Stepper\\_motor\\_3.png](http://en.wikipedia.org/wiki/Image:Stepper_motor_3.png)

[http://en.wikipedia.org/wiki/Image:Stepper\\_motor\\_2.png](http://en.wikipedia.org/wiki/Image:Stepper_motor_2.png)  
[http://en.wikipedia.org/wiki/Image:Stepper\\_motor\\_4.png](http://en.wikipedia.org/wiki/Image:Stepper_motor_4.png)

# uses of steppers



[http://home.fnal.gov/~carrigan/Pillars/Old\\_Fermlab\\_tape\\_robot.png](http://home.fnal.gov/~carrigan/Pillars/Old_Fermlab_tape_robot.png)

[http://commons.wikimedia.org/wiki/Image:Apple\\_Portable\\_StyleWriter.jpg](http://commons.wikimedia.org/wiki/Image:Apple_Portable_StyleWriter.jpg)

<http://commons.wikimedia.org/wiki/Image:Scanner.view.750pix.jpg>

# midterm project

<http://itp.nyu.edu/physcomp/Intro/MidtermAssignment>

- apply user testing knowledge to prototype
- make working prototype
- sketch details that aren't in the prototype
- present the whole process and the prototype

# assignment for next week

- midterm project: apply feedback to final prototype
- Lab: controlling a motor
- no reading
- keep writing in your journals, whatever inspires you